

OWNER'S MANUAL



HEEL GRAPPLE

OPERATION, MAINTENANCE, AND PARTS

CUSTOMER: _____

GRAPPLE MODEL: ED66 – 106D0343 **SERIAL:** _____

HEEL MODEL: _____ **SERIAL:** _____

MACHINE MAKE/MODEL: _____

MACHINE SERIAL: _____

Canada Parts / Product Support
Toll Free (North America) 1-800-208-2217
Phone (250) 286-9500 | Fax (250) 286-9501
USA Parts / Product Support
Roy Meier (360) 490-1215

*This machinery is excluded
from CWB certification scope
unless otherwise noted*

Factory / Head Office
5791 Duncan Bay Road
Campbell River, BC. V9H 1N6
www.t-mar.com

TABLE OF CONTENTS

ATTACHMENT WARRANTY	3
PARTS WARRANTY	5
WARRANTY REGISTRATION FORM	7
FLUSH SYSTEM	8
SAFE OPERATION	9
LOAD HOLDING VALVES	10
HEEL LENGTH	12
INSPECTION	13
MAINTENANCE	14
HYDRAULIC TROUBLESHOOTING	16
PARTS MANUAL PAGES:	
GRAPPLE ASSEMBLY	17
ROTATION MOTOR	20
TOP HEAD	22
MID SECTION	24
HYDRAULIC CYLINDER	26
SWIVEL	28
NARROW LEG	30
WIDE LEG	32
HYDRAULIC SCHEMATIC	34

Canada Parts / Product Support
 Toll Free (North America) 1-800-208-2217
 Phone (250) 286-9500
 Fax (250) 286-9501
USA Parts / Product Support
 Roy Meier (360) 490-1215



Factory / Head Office
 5791 Duncan Bay Road
 Campbell River, BC. V9H 1N6
www.t-mar.com

Design the best, build the best, for the best.

T-MAR Attachments – Limited Warranty Certificate

General Provisions – T-MAR Industries Ltd. (hereinafter referred to as “T-MAR”) warrants its attachments (hereinafter referred to as the “Product”) against defects in material or factory workmanship, subject to all terms and conditions stated herein, to the T-MAR Authorized Dealer (hereinafter referred to as the “Dealer”).

Warranty Coverage – All parts of the T-MAR product covered by this warranty which proves to be defective in material or workmanship. This warranty applies to all used, maintained, and serviced as intended, in compliance with/as directed in all applicable guidelines and instructions as set forth in the product manual. This warranty applies for a period of twelve (12) months, from the first day in service, so long as the first day in service is not later than eighteen (18) months from delivery to the dealer.

The warranty includes the labor performed by T-MAR or T-MAR Dealer. Proof of defect must be submitted within ten (10) days from the date of failure or defect discovery and any claim must be submitted within thirty (30) days from the date of submission of proof of failure or defect. The warranty extends only to the original purchaser (hereinafter referred to as the “Buyer”) of the Product and not to other purchasers or transferees unless agreed to in writing by T-MAR.

What is Not Warranted – T-MAR is not responsible for the following: (1) used Products; (2) defects caused by an alteration or modification of the Product not approved in writing by T-MAR; (3) depreciation or damage caused by normal wear; lack of reasonable and proper maintenance; failure to meet/comply with specifications and guidelines outlined by T-MAR; misuse; lack of proper protection during storage; or accident; (4) normal maintenance parts, fluids and service; (5) labor in diagnosis of a breakdown; (6) any defects resulting from the modification of factory pre-set pressures; and (7) expenses for miles or kilometers travelled.

Unintended or Unusual Use or Operation of the Product – The Product is designed and manufactured by T-MAR for use in certain specific applications, by properly qualified and trained personnel, in compliance with T-MAR’s manuals and all controlling federal, provincial and industry guidelines and regulations. Any other such use(s) or operation of the product shall be approved beforehand in writing by T-MAR.

Canada Parts / Product Support

Toll Free (North America) 1-800-208-2217

Phone (250) 286-9500

Fax (250) 286-9501

USA Parts / Product Support

Roy Meier (360) 490-1215



Factory / Head Office

5791 Duncan Bay Road

Campbell River, BC. V9H 1N6

www.t-mar.com

Design the best, build the best, for the best.

Warranty Service – In the event of any failure caused by a defect in material or in factory workmanship covered by this warranty, the Buyer shall: (1) notify T-MAR of the nature of the problem without a delay; and (2) stop using or operating the Product, unless authorized in writing by T-MAR. All warranty service shall be performed at the point of purchase of the Product either by T-MAR or a T-MAR Dealer using parts provided by T-MAR.

If the product was purchased directly from T-MAR, the Buyer shall return the Product or the defective parts “prepaid” to T-MAR without delay. If T-MAR deems that the parts are defective, it shall repair or replace the parts.

If the product was purchased from a Dealer, T-MAR shall provide the replacement parts to the Dealer. The Dealer shall install the parts and return the replaced parts to T-MAR, “prepaid” by the Buyer, within thirty (30) days of the repairs. The parts and their installation shall be without charge to the Buyer providing that the replaced parts are proven defective to T-MAR’s satisfaction. In all cases, all costs related to the transportation of parts or the Product to and from T-MAR or the Dealer, any premium charged for overtime labor requested by the Buyer or for any service and/or maintenance shall be the sole responsibility of the Buyer.

All parts replaced under warranty shall remain the property of T-MAR.

If the buyer fails to follow any of the above procedures or if the parts are not proven to be defective to T-MAR’s satisfaction, the Buyer shall not benefit from the warranty.

Limitation of Implied Warranties and Other Remedies – To the extent permitted by law, T-MAR does not make any warranties, representations or promises as to the quality, performance, or freedom from defect of the Product covered by this warranty. Implied warranties of merchantability and fitness for a particular purpose, to the extent applicable shall be limited in duration to the applicable period of warranty set forth herein. The Buyer’s only remedies of any warranties implied by a provincial and/or state law as hereby limited, the foregoing warranty is exclusive and replaces all other warranties, guarantees, agreements and similar obligations of T-MAR with respect to the repair or replacement of any part. In no event shall T-MAR be liable for incidental or consequential damages.

No Dealer Warranty – The Dealer has no authority to make any representation or promise on behalf of T-MAR, or to modify the terms or limitations of the warranty in any way.

Canada Parts / Product Support

Toll Free (North America) 1-800-208-2217

Phone (250) 286-9500

Fax (250) 286-9501

USA Parts / Product Support

Roy Meier (360) 490-1215



Factory / Head Office

5791 Duncan Bay Road

Campbell River, BC. V9H 1N6

www.t-mar.com

Design the best, build the best, for the best.

T-MAR Spare Parts (New & Remanufactured) – Limited Warranty Certificate

General Provisions – T-MAR Industries Ltd. (hereinafter referred to as “T-MAR”) warrants its Spare Parts (hereinafter referred to as the “Product”) against defects in material or factory workmanship, subject to all terms and conditions stated herein, to the T-MAR Authorized Dealer (hereinafter referred to as the “Dealer”).

Warranty Coverage – Structural component(s) of the T-MAR Product covered by this warranty which prove(s) to be defective in material or workmanship. This warranty applies to T-MAR manufactured components used, maintained and serviced as intended, in compliance with/as directed in all applicable guidelines and instructions as set forth in the product manual. This warranty applies for the period of six (6) months from the date of purchase. Proof of defect must be submitted within ten (10) days from the date of failure or defect discovery and any claim must be submitted within thirty (30) days from the date of submission of proof of failure/defect. The warranty extends only to the original purchaser (hereinafter referred to as the “Buyer”) of the Product and not to other purchasers or transferees unless agreed to in writing by T-MAR.

What is Not Warranted – T-MAR is not responsible for the following: (1) used Products; (2) defects caused by an alteration or modification of the Product not approved in writing by T-MAR; (3) depreciation or damage caused by normal wear; lack of reasonable and proper maintenance; failure to meet/comply with specifications and guidelines outlined by T-MAR; misuse; lack of proper protection during storage; or accident; (4) normal maintenance parts, fluids and service; (5) labor in diagnosis of a breakdown; (6) any defects resulting from the modification of factory pre-set pressures; and (7) expenses for miles or kilometers travelled.

Unintended or Unusual Use or Operation of the Product – The Product is designed and manufactured by T-MAR for use in certain specific applications, by properly qualified and trained personnel, in compliance with T-MAR’s manuals and all controlling federal, provincial/state and industry guidelines and regulations. Any other such use(s) or operation of the product shall be approved beforehand in writing by T-MAR.

Canada Parts / Product Support

Toll Free (North America) 1-800-208-2217

Phone (250) 286-9500

Fax (250) 286-9501

USA Parts / Product Support

Roy Meier (360) 490-1215



Factory / Head Office

5791 Duncan Bay Road

Campbell River, BC. V9H 1N6

www.t-mar.com

Design the best, build the best, for the best.

Warranty Service – In the event of any failure caused by a defect in material or in factory workmanship covered by this warranty, the Buyer shall: (1) notify T-MAR of the nature of the problem without a delay; and (2) stop using or operating the Product, unless authorized in writing by T-MAR. All warranty service shall be performed at the point of purchase of the Product either by T-MAR or by a Dealer using parts provided by T-MAR.

If the product was purchased directly from T-MAR, the Buyer shall return the Product or the defective parts “prepaid” to T-MAR without delay. If T-MAR deems that the parts are defective, it shall repair or replace the parts.

If the product was purchased from a Dealer, T-MAR shall provide the replacement parts to the Dealer. The Dealer shall install the parts and return the replaced parts to T-MAR, “prepaid” by the Buyer, within thirty (30) days of the repairs. The parts and their installation shall be without charge to the Buyer providing that the replaced parts are proven defective to T-MAR’s satisfaction. In all cases, all costs related to the transportation of parts or the Product to and from T-MAR or the Dealer, any premium charged for overtime labor requested by the Buyer or for any service and/or maintenance shall be the sole responsibility of the Buyer.

All parts replaced under warranty shall remain the property of T-MAR.

If the buyer fails to follow any of the above procedures or if the parts are not proven to be defective to T-MAR’s satisfaction, the Buyer shall not benefit from the warranty.

Limitation of Implied Warranties and Other Remedies – To the extent permitted by law, T-MAR does not make any warranties, representations or promises as to the quality, performance, or freedom from defect of the Product covered by this warranty. Implied warranties of merchantability and fitness for a particular purpose, to the extent applicable shall be limited in duration to the applicable period of warranty set forth herein. The Buyer’s only remedies of any warranties implied by a provincial and/or state law as hereby limited, the foregoing warranty is exclusive and replaces all other warranties, guarantees, agreements and similar obligations of T-MAR with respect to the repair or replacement of any part. In no event shall T-MAR be liable for incidental or consequential damages.

No Dealer Warranty – The Dealer has no authority to make any representation or promise on behalf of T-MAR, or to modify the terms or limitations of the warranty in any way.

Canada Parts / Product Support

Toll Free (North America) 1-800-208-2217

Phone (250) 286-9500

Fax (250) 286-9501

USA Parts / Product Support

Roy Meier (360) 490-1215



Factory / Head Office

5791 Duncan Bay Road

Campbell River, BC. V9H 1N6

www.t-mar.com

Design the best, build the best, for the best.



T-MAR INDUSTRIES LTD.

FORESTRY ATTACHMENTS WARRANTY REGISTRATION

IMPORTANT:

*This form must be completed and on file at T-MAR for warranty claims to be considered –
EMAIL TO: warranty@t-mar.com*

ATTACHMENT

MODEL NUMBER:	SERIAL NUMBER:
CARRIER MAKE & MODEL:	SERIAL NUMBER:
DELIVERY/FIRST USE DATE:	

DEALER

NAME:	BRANCH:
CONTACT:	PHONE NUMBER:

OWNER

NAME:	CITY:
CONTACT:	PHONE NUMBER:

DEALER ACKNOWLEDGEMENT

Dealer: The Warranty Registration, signed by the End User, must be submitted within **30 days** of the Delivery Date to register the attachment in the T-MAR warranty system. Along with a copy of Bill of Sale, Rental agreement or other supporting document. Claims will not be considered without registration. The Warranty period begins on first use or delivery to customer.

OWNERS ACKNOWLEDGEMENT

I confirm that the above identified attachment, was delivered complete with:

Warranty Certificate ____

Operator, Maintenance & Parts Manual ____

The safe and proper operation and maintenance of the attachment and the correct use of all controls has been completely explained including how to flush the system before installing the attachment.

I have read and understand both the Certificate and the Registration.

Customer Signature: _____ Date: _____

Print Name: _____

FLUSH SYSTEM BEFORE CONNECTING GRAPPLE

The following steps will replenish the hydraulic lines with fresh oil and deliver any contaminants to the return filter on the machine. This procedure should be performed any time a new attachment is fitted on a machine.

1. Connect the open and close hoses together at the tip of the stick.
2. Run the open or close function for thirty (30) seconds in one direction.
3. Repeat steps 1 & 2 with the rotation hoses.

Additional steps should be taken when a failed hydraulic component is replaced on an attachment. In this case, the lines should be looped where they would normally attach to the failed component, such that the entire circuit is flushed back to tank before the replacement component is installed. If a failed component introduced metal contamination to the open-close system, both cylinders should also be disassembled and thoroughly cleaned to remove and accumulated contamination.

SYSTEM CONTAMINATION IS THE LEADING CAUSE OF COMPONENT FAILURE. MOST OIL IN THE GRAPPLE CIRCUIT DOES NOT CIRCULATE BACK TO THE TANK DURING REGULAR OPERATION.

Canada Parts / Product Support

Toll Free (North America) 1-800-208-2217

Phone (250) 286-9500

Fax (250) 286-9501

USA Parts / Product Support

Roy Meier (360) 490-1215



Factory / Head Office

5791 Duncan Bay Road

Campbell River, BC. V9H 1N6

www.t-mar.com

Design the best, build the best, for the best.

SAFE OPERATION

- **Operators must read and understand the information provided in this manual before attempting to operate this attachment.**
- **Failure to follow these instructions may void warranty and may result in equipment damage and/or injury or death.**
- **This attachment and the machine to which it is attached should only be operated by trained personnel who are familiar with the use of this type of equipment.**
- **Do not lift, carry or suspend loads near people or equipment, or in a way that a dropped load could strike a person or equipment.**
- **Do not operate this equipment near overhead powerlines.**
- **Do not operate this equipment under the influence of drugs or alcohol.**
- **The attachment and base machine shall be inspected before every use. Any deficiencies found during inspection that could affect the safe use of the system shall be corrected before the machine is used.**
- **This attachment is designed for the handling of felled logs in a timber harvesting application. The attachment is not designed for any other use.**
- **The rotation motor is intended for grapple positioning only. Do not use the rotate function while handling logs.**



Canada Parts / Product Support

Toll Free (North America) 1-800-208-2217

Phone (250) 286-9500

Fax (250) 286-9501

USA Parts / Product Support

Roy Meier (360) 490-1215



Factory / Head Office

5791 Duncan Bay Road

Campbell River, BC. V9H 1N6

www.t-mar.com

Design the best, build the best, for the best.

LOAD HOLDING VALVES

- **This attachment is equipped with counterbalance type load holding valves to reduce the chance of undesired grapple leg movement in case of hose rupture, etc.**
- **Replacement with any load holding valves other than those approved by the factory will void the grapple warranty.**
- **The grapple should never be forced into the ground unless the legs are fully open and the “grapple open” function is held active.**
- **Never swing the grapple legs or the load being held by the grapple into a fixed object.**
- **This grapple was not designed for the removal of stumps (stump pulling).**
- **This grapple was not designed to assist in machine positioning. The heel rack may be used for this purpose.**
- **Failure to follow these instructions may void warranty, and may result in equipment damage, injury, or death.**



Canada Parts / Product Support

Toll Free (North America) 1-800-208-2217

Phone (250) 286-9500

Fax (250) 286-9501

USA Parts / Product Support

Roy Meier (360) 490-1215



Factory / Head Office

5791 Duncan Bay Road

Campbell River, BC. V9H 1N6

www.t-mar.com

Design the best, build the best, for the best.

COUNTERBALANCE LOAD HOLDING VALVES

- Counterbalance valves will hold applied and induced pressures inside the grapple cylinders up to a set pressure limit.
- Fluid will relieve when this limit is exceeded.
- This is designed to prevent cylinder damage and mechanical failure.
- If the load exceeds the design limit of the grapple this system can cause undesired grapple leg movement which may result in loads being released.

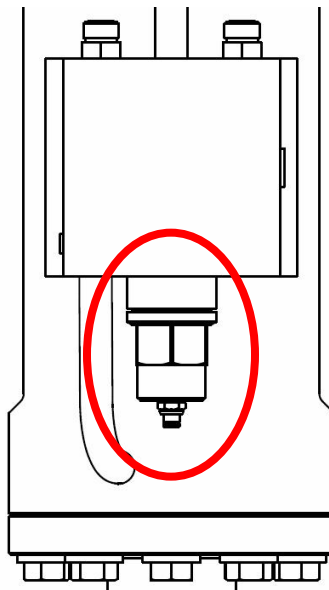

COUNTERBALANCE VALVE

Canada Parts / Product Support

Toll Free (North America) 1-800-208-2217

Phone (250) 286-9500

Fax (250) 286-9501

USA Parts / Product Support

Roy Meier (360) 490-1215



Factory / Head Office

5791 Duncan Bay Road

Campbell River, BC. V9H 1N6

www.t-mar.com

Design the best, build the best, for the best.

HEEL LENGTH

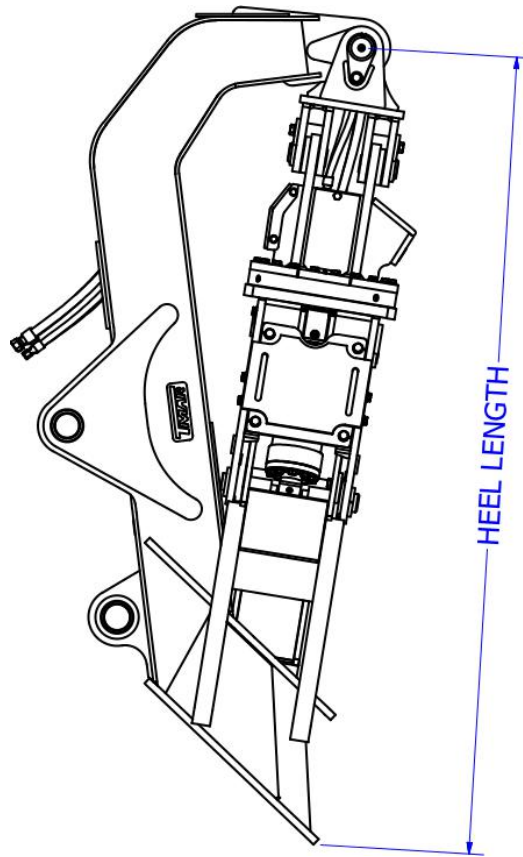

GRAPPLE		SOLID LINK	PASSTHRU LINK
106D0343	ED66 MK3	112"	117"

- Optimal heel length is listed for the grapple.
- A heel length 10% or more shorter than the listed value is generally not acceptable.
- Consult T-MAR engineering department for further information.

Canada Parts / Product Support

Toll Free (North America) 1-800-208-2217

Phone (250) 286-9500

Fax (250) 286-9501

USA Parts / Product Support

Roy Meier (360) 490-1215



Factory / Head Office

5791 Duncan Bay Road

Campbell River, BC. V9H 1N6

www.t-mar.com

Design the best, build the best, for the best.

INSPECTION

- **The attachment and base machine shall be inspected before every use. Any deficiencies found during inspection that could affect the safe use of the system shall be corrected before the machine is used.**
- **Check all surfaces and weld joints for signs of cracks or deformation.**
- **Ensure that all guards are installed.**
- **Check that all fasteners are present and tight.**
- **Inspect all pin bores for bushing wear. Signs or wear include excess clearance between the pin and the bushing or an oval shaped bore.**
- **Ensure that all grease fittings are present, undamaged and functional.**
- **Inspect the hydraulic fittings and components for any signs of leakage.**
- **Inspect the hydraulic hoses for wear or deformation.**

Canada Parts / Product Support

Toll Free (North America) 1-800-208-2217

Phone (250) 286-9500

Fax (250) 286-9501

USA Parts / Product Support

Roy Meier (360) 490-1215

**Factory / Head Office**

5791 Duncan Bay Road

Campbell River, BC. V9H 1N6

www.t-mar.com

Design the best, build the best, for the best.

MAINTENANCE

- Regular maintenance is essential to the longevity and safe use of this attachment. Failure to follow these instructions voids warranty and may result in equipment damage, injury, or death.
- Never attempt a repair that you are not qualified to perform or do not fully understand.
- It is recommended that only T-MAR genuine parts are used in the repair and maintenance of this attachment. Use of unapproved components may void warranty.
- All components must be lubricated with moly EP grease at the intervals in the below chart:

PASS THRU LINK

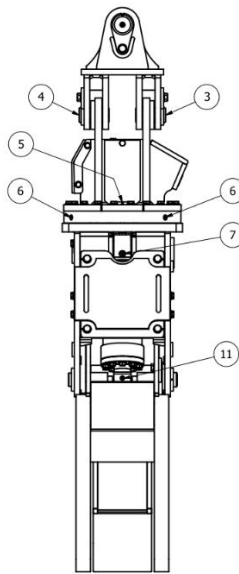
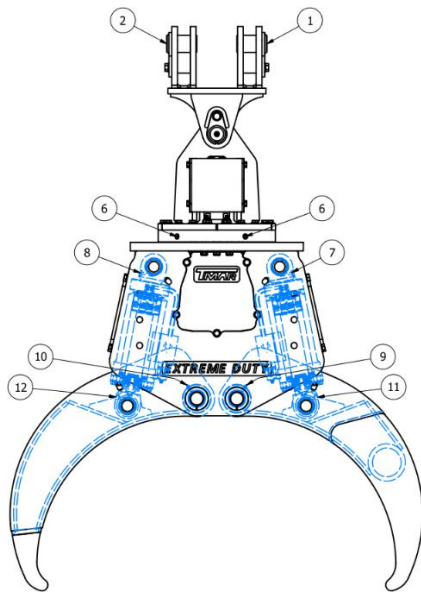

LUBRICATION CHART			
ITEM	QTY.	DESCRIPTION	INTERVAL
1	1	LINK TO HEEL PIN	TWICE DAILY
2	1	LINK TO HEEL PIN	TWICE DAILY
3	1	LINK TO TOP HEAD PIN	TWICE DAILY
4	1	LINK TO TOP HEAD PIN	TWICE DAILY
5	2	GRAPPLE ROTATE GEAR	TWICE DAILY
6	4	BEARING	ONCE DAILY
7	1	CYLINDER TAILHOLD PIN	TWICE DAILY
8	1	CYLINDER TAILHOLD PIN	TWICE DAILY
9	2	LEG PIVOT PIN	TWICE DAILY
10	2	LEG PIVOT PIN	TWICE DAILY
11	1	CYLINDER ROD END PIN	TWICE DAILY
12	1	CYLINDER ROD END PIN	TWICE DAILY

Canada Parts / Product Support

Toll Free (North America) 1-800-208-2217

Phone (250) 286-9500

Fax (250) 286-9501

USA Parts / Product Support

Roy Meier (360) 490-1215



Factory / Head Office

5791 Duncan Bay Road

Campbell River, BC. V9H 1N6

www.t-mar.com

Design the best, build the best, for the best.

MAINTENANCE CONT'D

SOLID LINK

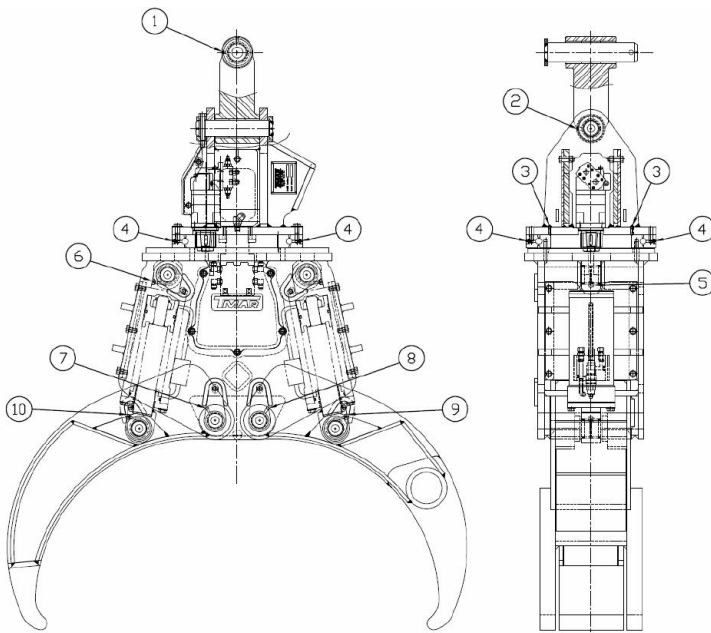

ITEM	QTY.	DESCRIPTION	INTERVAL
1	1	Link To Heel Pin	Twice Daily
2	1	Link To Tophead Pin	Twice Daily
3	2	Tophead Bearing Gear	Twice Daily
4	4	Bearing	Once Daily
5	1	Cylinder Tailhold Pin	Twice Daily
6	1	Cylinder Tailhold Pin	Twice Daily
7	2	Leg Pivot Pin	Twice Daily
8	2	Leg Pivot Pin	Twice Daily
9	1	Cylinder Rod End Pin	Twice Daily
10	1	Cylinder Rod End Pin	Twice Daily

Canada Parts / Product Support

Toll Free (North America) 1-800-208-2217

Phone (250) 286-9500

Fax (250) 286-9501

USA Parts / Product Support

Roy Meier (360) 490-1215



Factory / Head Office

5791 Duncan Bay Road

Campbell River, BC. V9H 1N6

www.t-mar.com

Design the best, build the best, for the best.

TESTING HYDRAULIC OPEN/CLOSE CIRCUIT

T-MAR GRAPPLES - WHEN LEGS DRIFT DOWN FROM FULLY OPEN

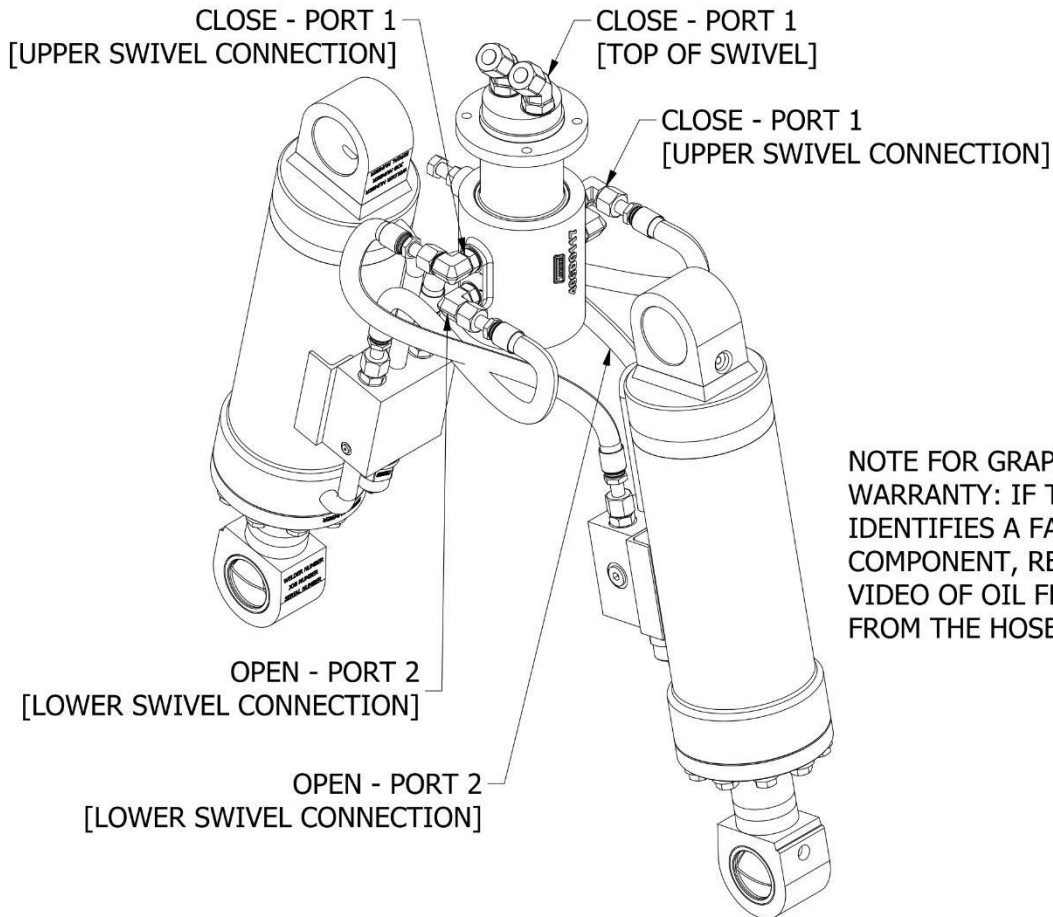

NOTE FOR GRAPPLES UNDER WARRANTY: IF THIS TEST IDENTIFIES A FAILED COMPONENT, RECORD A VIDEO OF OIL FLOWING FROM THE HOSE OR FITTING

BRING MACHINE HYDRAULIC OIL UP TO OPERATING TEMPERATURE BEFORE STARTING TEST

1. FULLY OPEN GRAPPLE AND PLACE LEGS ON FIRM GROUND
 2. DISCONNECT "GRAPPLE CLOSE" HOSE FROM FITTING ON TOP OF SWIVEL [PORT 1]. CAP FITTING & PLUG HOSE
 2. DISCONNECT "GRAPPLE CLOSE" HOSES FROM GRAPPLE CYLINDERS, LEAVE CONNECTED TO SWIVEL
 3. LEAVE "GRAPPLE CLOSE" FITTINGS ON CYLINDERS UNCAPPED
 4. PULL "GRAPPLE CLOSE" HOSE ENDS OUT THROUGH SIDE DOORS AND SECURE ENDS INTO EMPTY PAILS
 5. CAREFULLY RUN GRAPPLE OPEN FUNCTION. **CAUTION:** A LARGE VOLUME OF HIGH PRESSURE OIL MAY EJECT FROM THE "GRAPPLE CLOSE" HOSES IF THE SWIVEL HAS FAILED. STAND CLEAR AND WEAR APPROPRIATE PPE
- IF OIL FLOWS INTO PAIL FROM GRAPPLE OPEN HOSES, SWIVEL WILL NEED TO BE REBUILT OR REPLACED
- IF OIL FLOWS OUT OF GRAPPLE CLOSE FITTING ON ONE OR BOTH OF THE CYLINDERS, CYLINDER IS BYPASSING INTERNALLY AND WILL NEED TO BE REBUILT OR REPLACED
- IF NO OIL FLOWS FROM OPEN HOSES & FITTINGS, PERFORM FOLLOWING TEST:
1. DISCONNECT "GRAPPLE OPEN" HOSE FROM FITTING ON TOP OF SWIVEL [PORT 2]. CAP FITTING & PLUG HOSE
 2. RECONNECT "GRAPPLE CLOSE" HOSES FROM SWIVEL TO GRAPPLE CYLINDERS
 3. LIFT THE GRAPPLE UP FROM THE GROUND WITH THE MACHINE
- IF LEGS DO NOT DRIFT DOWN, CHECK MACHINE CONTROL VALVE FOR OIL BYPASS

Canada Parts / Product Support

Toll Free (North America) 1-800-208-2217

Phone (250) 286-9500

Fax (250) 286-9501

USA Parts / Product Support

Roy Meier (360) 490-1215



Factory / Head Office

5791 Duncan Bay Road

Campbell River, BC. V9H 1N6

www.t-mar.com

Design the best, build the best, for the best.

Assembly, 66" Extreme Duty MK3 Grapple**Ref. No:****606B1193****Rev. L**

Ref.	Part No:	Description	Qty.
---	106D0343	Complete Assembly	---
1	206D0324	Top Head	1
2	206D0311	Mk3 Mid Section Assembly	1
3	206B1063	66" Wide Leg Assembly	1
4	206B1059	66" Narrow Leg Assembly	1
5	270C0094	Cylinder Assembly	2
6	343B0011	Grapple Slew Bearing	1
7	206B1204	High Pressure Swivel Assembly	1
8	371B0016	Rotation Motor Assembly	1
9	371C0047	Cross Port Relief Manifold	1
10	371A0120	Relief Valve Cartridge	2
11	340B0241	Ø2 1/2 Pin, Cylinder Tail End	2
12	340B0240	Ø2 1/2 Pin, Cylinder Rod End, Wide Leg	1
13	340B0239	Ø2 1/2 Pin, Cylinder Rod End, Narrow Leg	1
14	340B0270	Leg Pin	2
15	306B1106	Pin Shaft	1
16	406A0113	Pin-Lock	4
17	406B1117	Pin Retainer	1
18	306B0198	Pinion Gear, 15T	1
19	345A0168	Pin Anti-Rotation Tab	2
20	345A0061	Weld-on Retainer	2
21	333A0103	Weld-On Serial Plate, 106D0343	1
22		SOCKET HD CAPSCREW 3/8 - 16 UNC X 1 3/4	4
23	FCSCBSC12-134	FLANGE 12-POINT CAPSCREW 1/2 - 13 UNC X 1 3/4	4
24	345A0015	Washer 1/2 X .15 Thick	4
25		HEX HD CAPSCREW M14 X 2.0 X 50	4
26	SHP.40255	LOCKWASHER M14	4
27	SHP.0122078	HEX HD CAPSCREW M16 X 2.0 X 60	21
28	SHP.40762	HEX HD CAPSCREW M16 X 2.0 X 70	20
29	SHP.40768	HEX HD CAPSCREW M16 X 2.0 X 120	1
30	SHP.34882	FLAT WASHER M16, HARD	40
31	SHP.90711	HEX NUT M16 X 2	3
32	SHP.40776	HEX HD CAPSCREW M20 X 2.5 X 40	2

Assembly, 66" Extreme Duty MK3 Grapple**Ref. No:****606B1193****Rev. L**

Ref.	Part No:	Description	Qty.
33	SHP.40777	HEX HD CAPSCREW M20 X 2.5 X 45	2
34	SHP.34883	FLAT WASHER M20, HARD	4
35	FCP532-212	COTTER PIN 5/32 X 2 1/2	1
36	50HP-8	Hex Socket Plug, -8 ORB	2
37	58C-8	Cap, -8 FFFO	2
38	5650-8-8	Straight Fitting, -8 MORB to -8 MORF	2
39	5652-10-10	Elbow, 90, -10 MORF to -10 MORB	4
40	58C-12	Cap, -12 FFFO	2
41	5650-12-12	Adapter, -12 MORF to -12 MORB	2
42	OR2-12	O-Ring, Code 62, 90A	2
43	72A6050 CL28	Hose Assembly	4
44	345A0068	1/8" NPT Grease Fitting	2
45	345A0042	Shim, 1/8" Thick (For Legs and Cylinders)	1
46	345A0043	Shim, 1/16" Thick (For Legs and Cylinders)	1
47	206A0699	Fitting Kit, ED 125mm Grapple	1
48	206A0698	Fastener Kit, ED MK3 Grapple	1

Notes:

1. Grapples with a serial number before 16776 use hose # 72A6039 CL28 in place of item 43.
2. Jump-size fittings are required when replacing a swivel or cylinder on a grapple with a s/n before 16776. Cylinder replacement requires 2x 5650-8-10. Swivel replacement requires 4x 5652-8-10.

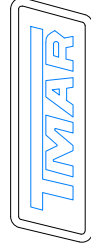
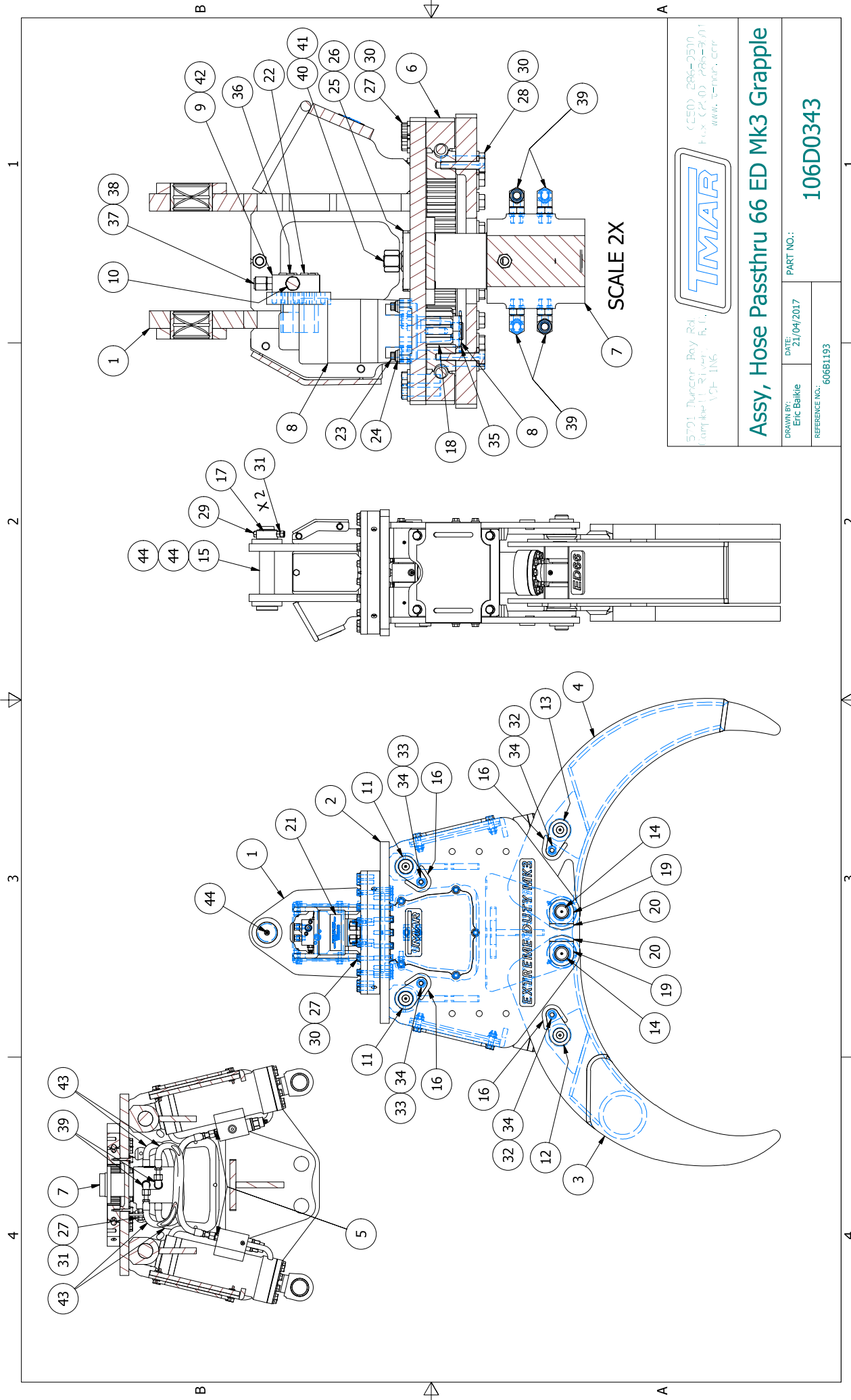

5701 Turner Roy Rd.
 Campbell River, B.C.
 V9P 1N6
 (250) 286-9500
 Fax: (250) 286-9101
 www.tamar-ccr.com

Assy, Hose Passthru 66 ED MK3 Grapple

DRAWN BY: Eric Bakke	DATE: 21/04/2017	PART NO.:
REFERENCE NO.:	106D0343	
606B1193		

Assembly, Rotation Motor
Applicable Serial Numbers:

All Units

Ref. No: 671B0163
Rev. A

Ref.	Part No:	Description	Qty.
---	371B0016	Complete Assembly	---
1	---	Motor, Char Lynn	1
2	---	Nut, 1 1/4 - 18 UNEF, Castelated	4
3	---	CF. Square, 7/16" x 1 1/4" Long	1

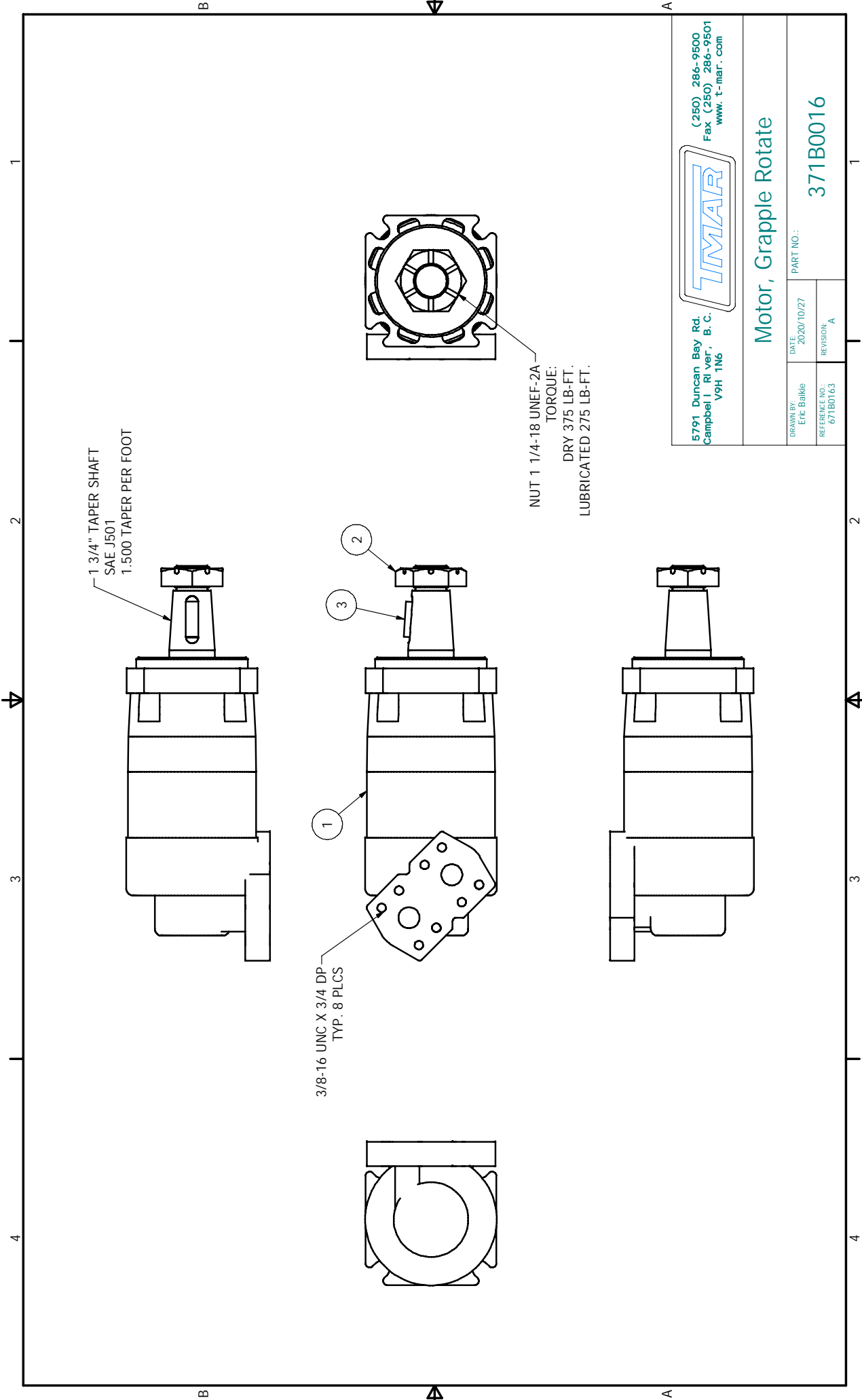

1 3/4" TAPER SHAFT
SAE J501
1.500 TAPER PER FOOT

3/8-16 UNC X 3/4 DP
TYP. 8 PLCS

NUT 1 1/4-18 UNEF-2A
TORQUE:
DRY 375 LB-FT.
LUBRICATED 275 LB-FT.

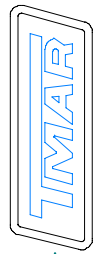

5791 Duncan Bay Rd.
Campbell, RI Ver., B. C.
V9H 1N6
(250) 286-9500
Fax (250) 286-9501
www.t-mar.com

Motor, Grapple Rotate

DRAWN BY: Eric Baillie	DATE: 2020/10/27	PART NO.:
REFERENCE NO.:671B0163	REVISION: A	371B0016

Assembly, Top Head

Ref. No: 606B1128

Rev. _

Ref.	Part No:	Description	Qty.
---	206D0324	Complete Assembly	---
1	306D0325	Top Head	1
2	306B1264	Motor Guard	1
3	406B1120	Side Guard	2
4	342B0057	Bushing, 3 OD x 2 1/2 ID x 2 LG	2
5		HEX HD BOLT M14 X 2 X 40	4
6		FLAT WASHER M14, HARD	4
7		HEX HD BOLT M16 X 2 X 50	2
8	SHP.90711	HEX NUT M16 X 2	2
9	345A0068	1/8" NPT Grease Fitting	2
10	206D0324-FK	Fastener Kit (Includes Items 4-9)	1

Notes:

- 1.) Use with Hydraulic Swivels with 4" pilot only.

1 2 3 4

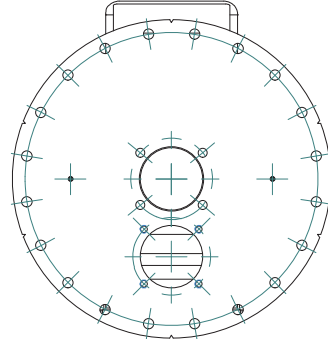

VIEW B-B

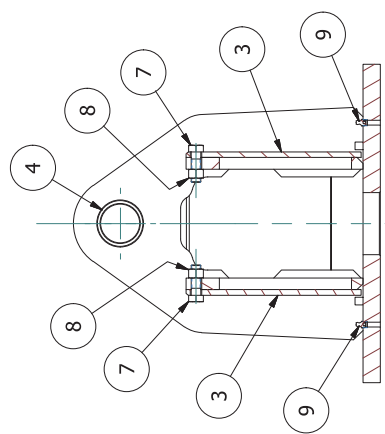

SECTION A-A

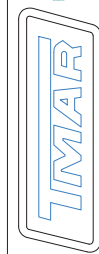
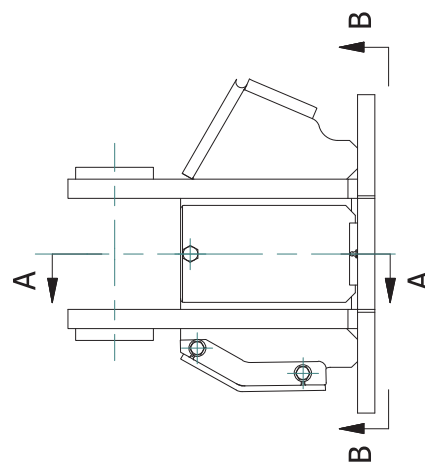
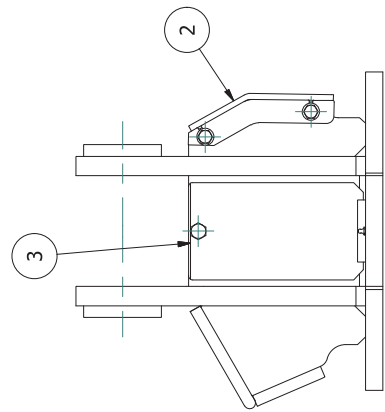
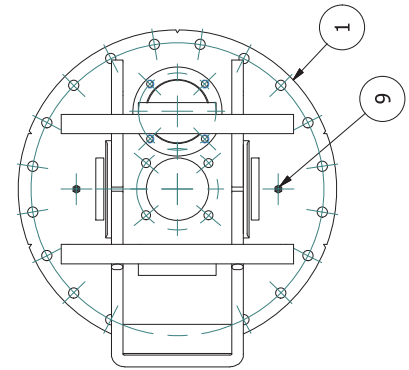

5791 Durcan Bay Rd.
 Complex 10 River, B.C.
 V9H 1N6
 (250) 286-9500
 Fax (250) 286-9501
 www.t-mar.com

Top Head Assembly, MKIII

DRAWN BY: Eric Baikie
 DATE: 09/05/2016
 PART NO.: 206D0324
 REFERENCE NO.: 606B1128

1 2 3 4

Assembly, Mid Section

Ref. No: 606B1135

Rev. 0

Ref.	Part No:	Description	Qty.
---	206D0311	Complete Assembly	---
1	306D0312	Mid Section	1
2	306B1115	Side Guard	2
3	306B0116	Front Guard	2
4		HEX HD BOLT M16 X 2 X 50	10
5		FLAT WASHER M16, HARD	10
6		HARDENED FLAT WASHER M20	16
7		HEX HD BOLT M20 X 2.5 X 65	8
8		PREVAILING TORQUE HEX NUT M20 X 2.5	8
9	306A0697	Anti-Rotation Tab	1
10	206D0311-FK	Fastener Kit (Includes Items 4-8)	1

Notes:

Pin Lock Part No. 406A0113

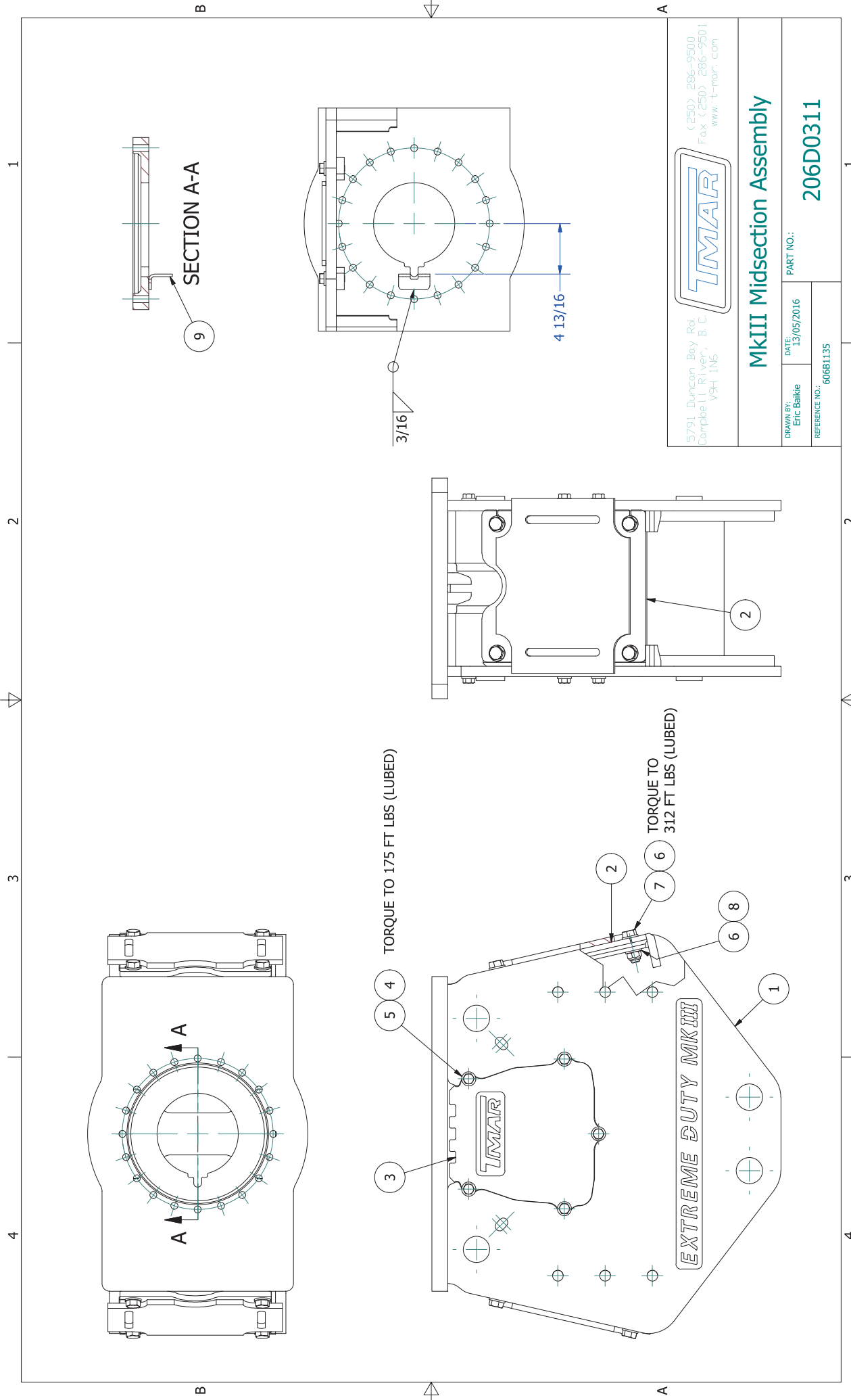



 5791 Durston Bay Rd. (250) 286-9500

 Complete Driverv, B.C. Fax: (250) 286-9501

 V5H LING www.t-mar.com

MKIII Midsection Assembly

DRAWN BY: Eric Baikie	DATE: 13/05/2016	PART NO.: 206D0311
REFERENCE NO.: 606B1135		

Assembly, 125mm Cylinder, 12" Stroke, -10 Ports**Ref. No:****670B0275****Applicable Serial Numbers:**

All Units

Rev. A

Ref.	Part No:	Description	Qty.
---	270C0094	Complete Assembly	---
1	370C0093	Cylinder Barrel	1
2	370B0242	Rod, Cylinder	1
3	370C0092	Piston, Cylinder	1
4	370C0086	Gland, Cylinder	1
5	370B0161	Nut, Piston	1
6	370A0055	Shim	1
7	370A0068	Stopper	2
8	370A0099	Ring Spacer	1
9	370A0065	Ring, Cushion	1
10	347A0180	Cushion Seal	1
11	347A0314	Seal Assembly	1
12	347A0235	Rod Seal	1
13	347A0236	Backup Ring	1
14	347A0172	Rod Wiper	1
15	347A0237	Wear Ring, Rod	1
16	347A0345	Wear Ring	1
17	347A0315	O-Ring	1
18	347A0316	Back Up Ring	1
19	347A0346	Wear Ring	1
20	371A0417	Counterbalance Valve	1
21	SHP.34882	FLAT WASHER M16, HARD	10
22	SHP.0122078	HEX HD CAPSCREW M16 X 2.0 X 60	10
23	50HP-2	Hex Socket Plug, -2 ORB	1
24	5650-10-10	Adapter, -10 MORF to -10 MORB	2
25	50HP-10	Hex Socket Plug, -10 ORB	1
26	372B0580	Cartridge Retainer	1
27	SHP.40694	HEX HD CAPSCREW M10 X 1.5 X 30	1
28	SHP.40223	FLAT WASHER M10	1
29	342B0055	Bushing	2
30	270A0086	Fastener Kit	1
31	247A0347A	Seal Kit, Piston & Gland	1

Notes:

1. Exchange cylinders are available on a cost-of-repair basis.

1 2 3 4

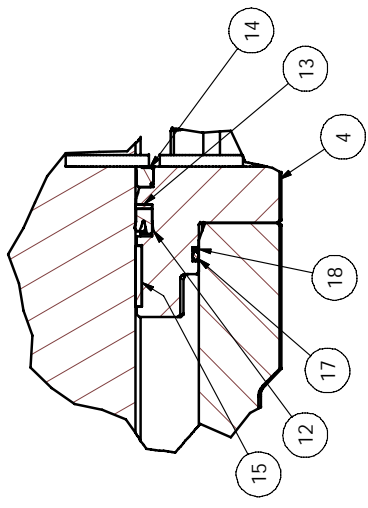
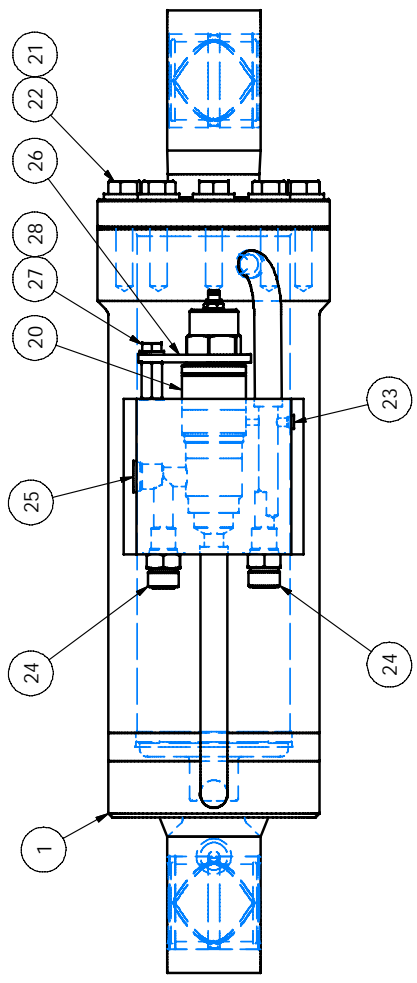

DETAIL A
SCALE 1 / 2

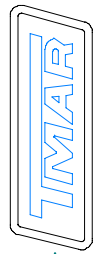
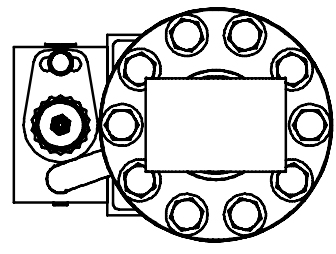
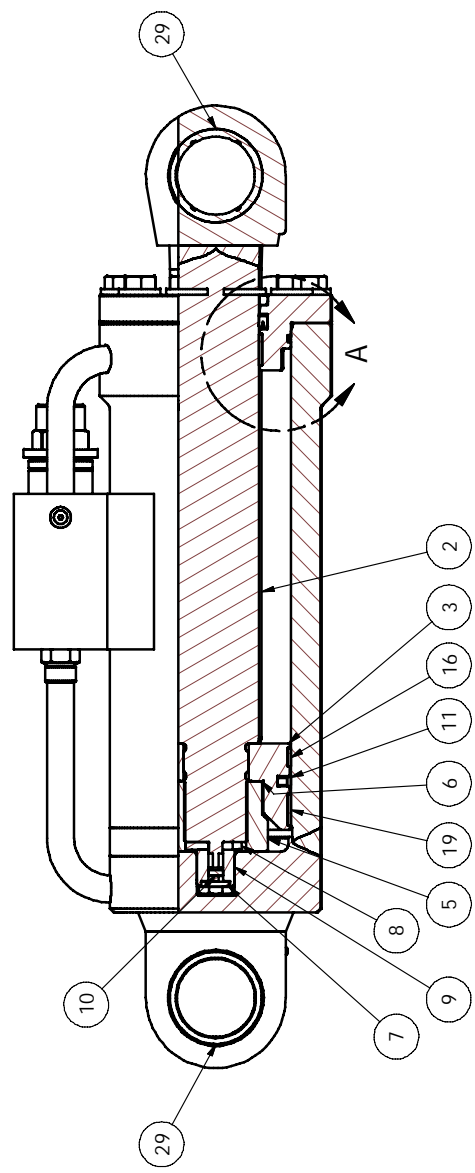

5791 Duncan Bay Rd.
Campbell I. RI ver. B. C.
V9H 1N6

(250) 286-9500
Fax (250) 286-9501
www.t-mar.com

Assembly, 125mm Cyl, 12" Stroke, -10

DRAWN BY: Eric Baillie	DATE: 05/07/2018	PART NO.:
REFERENCE NO.:670B0275	REVISION: A	270C0094

1

2

3

4

B

A

A

Assembly, Swivel (HP)

Ref. No: 606B1314

Rev. 0

Ref.	Part No:	Rev.	Description	Qty.
---	206B1204		Complete Assembly	---
1	306B0512		Swivel Core Weldment	1
2	306D0351		Housing, Swivel Outer	1
3	343A0015		Bearing	1
4	348A0023		Retaining Ring, Internal	1
5	348A0012		Retaining Ring, External	1
6	347A0013		Seal, U-Cup	2
7	347A0014		Backup Ring	2
8	347A0015		Wiper, Metal Clad	1
9	347A0188		Seal Ring, Carbon Teflon	1
10	347A0189		Seal, Square Ring	1
11	206A0658		Seal Kit (Includes Items 4-10)	1

Notes:

- 1.) Exchange swivels are available on a cost-of-repair basis.
- 2.) Swivel core top ports: -12 ORB x 2.
- 3.) Swivel housing side ports: -10 ORB x 4.
- 4.) Mounting Hardware:
 - SHP.40738 (M14 X 2.0 X 50) x 4
 - SHP.40386 (M14 lock washer) x 4
 - GTSOR-10 #10 ORB O-rings x 4
 - GTSOR-12 #12 ORB O-rings x 2

1 2 3 4

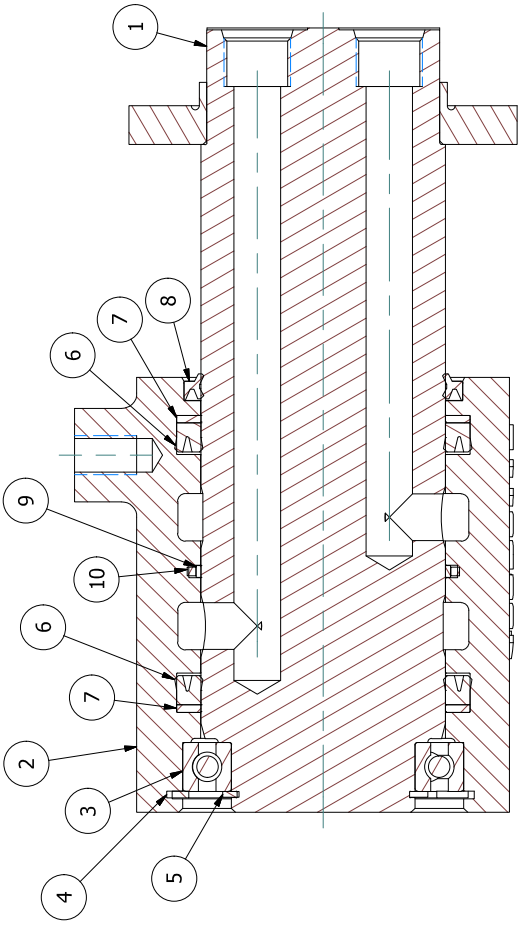
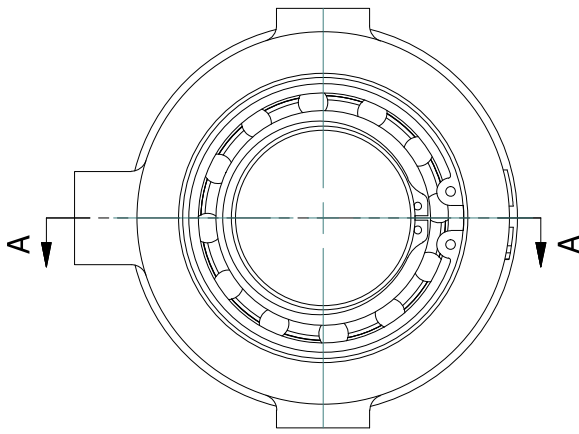

SECTION A-A

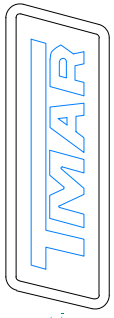

5791 Duncan Bay Rd.
 Campbell River, B.C.
 V9H 1N6
 (250) 286-9500
 Fax (250) 286-9501
 www.t-mar.com

Assembly, Swivel (HP), -10 Ports

DRAWN BY: Eric Baikie	DATE:	05/07/2018	DWG NO: 206B1204
	REF:	606B1314	

Assembly, 66" ED Mk3 Narrow Leg Assembly
Applicable Serial Numbers: All Units

Ref. No: **606B1191**
Rev. A

Ref.	Part No:	Description	Qty.
---	206B1059	Complete Assembly	---
1	306D0245	66" Narrow Leg Weldment	1
2	342B0056	Bushing	2
3	345A0068	1/8" NPT Grease Fitting	2

Notes:

1. Grapples with a serial number before 16666 use spacer 306A0114 between bushings

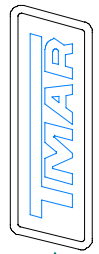
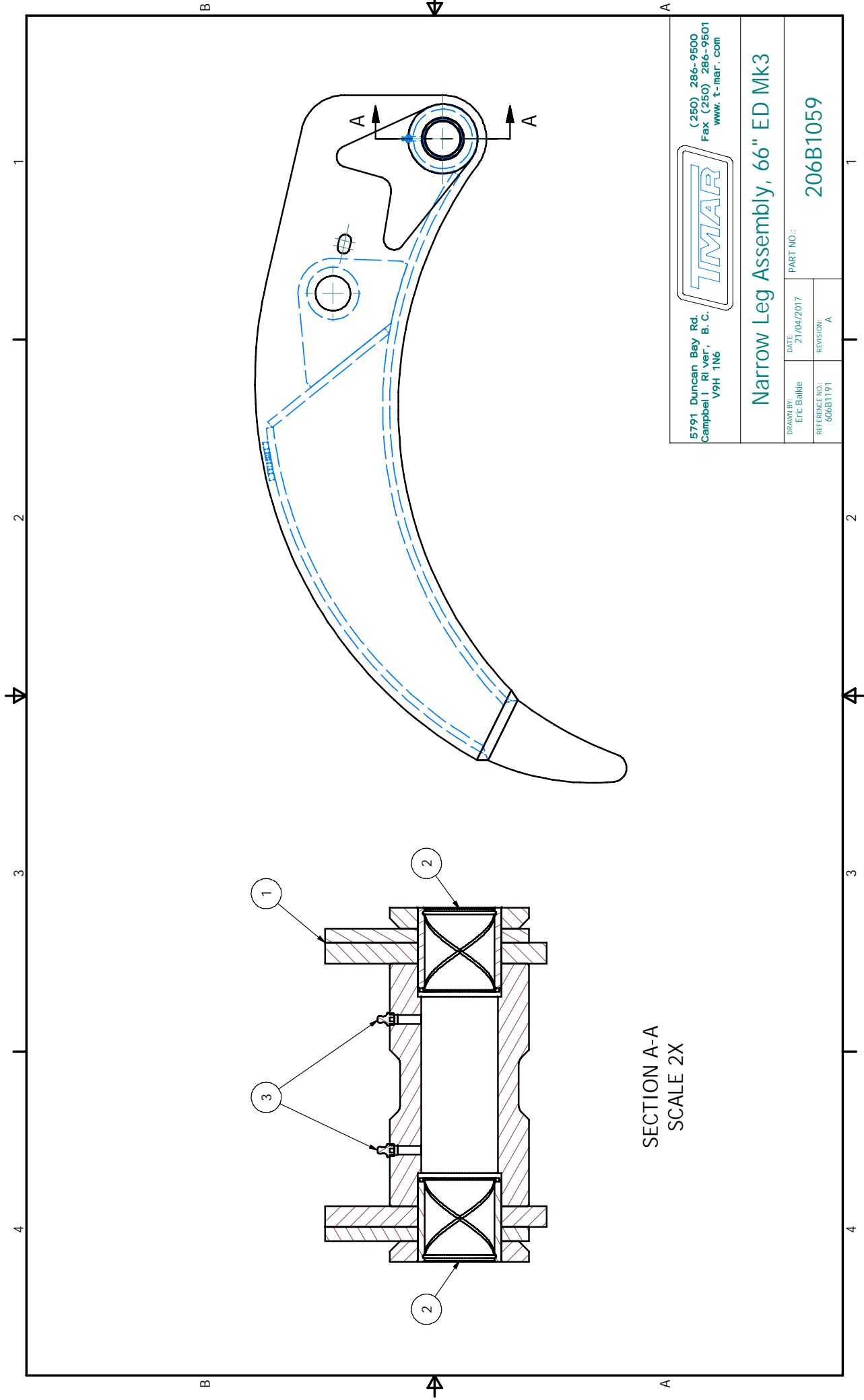

5791 Duncan Bay Rd.
Campbell I. RI ver. B. C.
V9H 1N6

(250) 286-9500
Fax (250) 286-9501
www.t-mar.com

Narrow Leg Assembly, 66" ED Mk3

DRAWN BY: Eric Baillie	DATE: 21/04/2017	PART NO.:
REFERENCE NO.:606B1191	REVISION: A	206B1059

SECTION A-A
SCALE 2X

Assembly, 66" ED Mk3 Wide Leg Assembly

Ref. No: 606B1192

Applicable Serial Numbers: All Units

Rev. A

Ref.	Part No:	Description	Qty.
---	206B1063	Complete Assembly	---
1	306D0314	66" Wide Leg Weldment	1
2	342B0056	Bushing	2
3	345A0068	1/8" NPT Grease Fitting	2

Notes:

1. Grapples with a serial number before 16666 use spacer 306A0114 between bushings

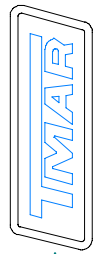
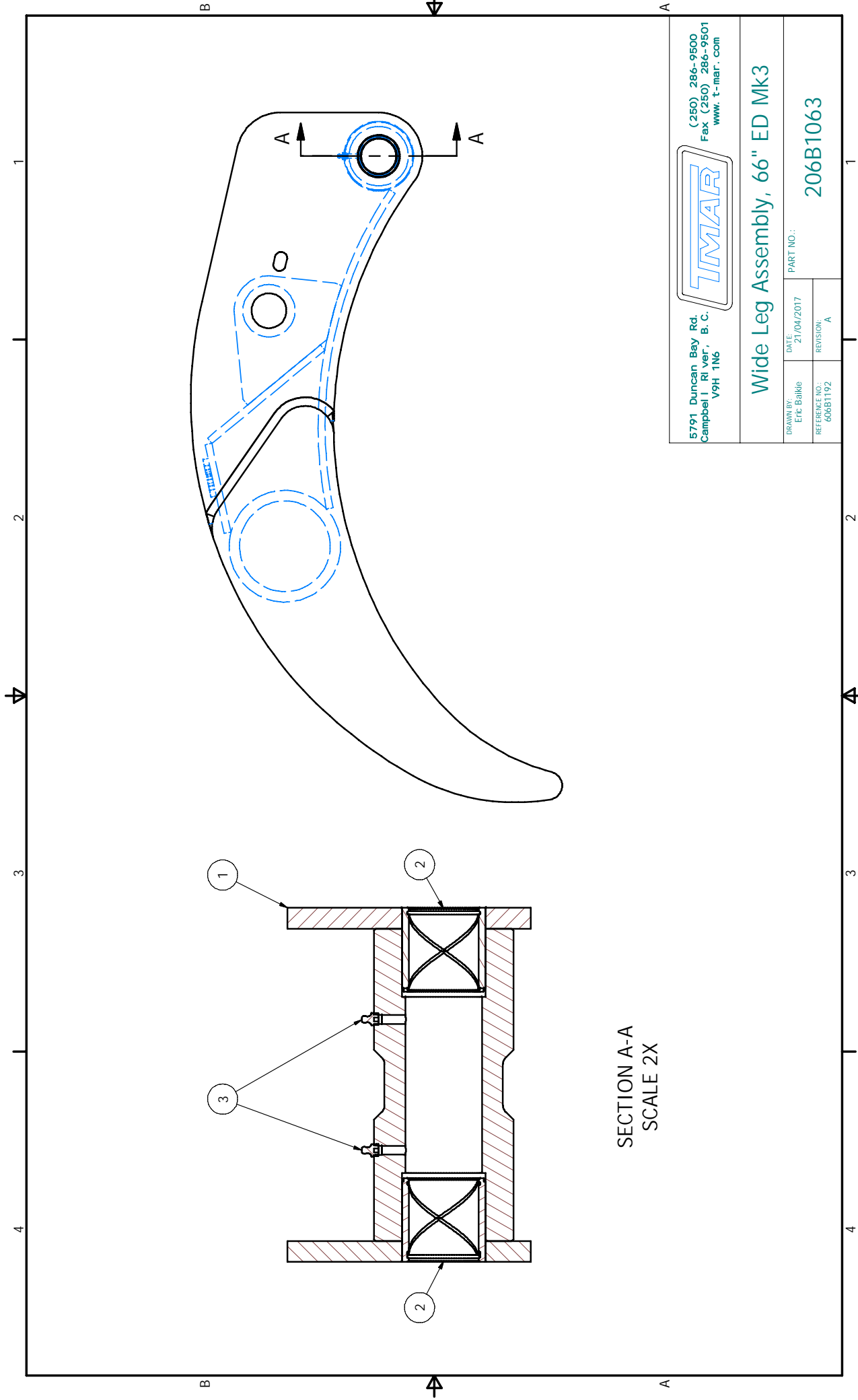

5791 Duncan Bay Rd.
 Campbell I. RI ver. B. C.
 V9H 1N6
 (250) 286-9500
 Fax (250) 286-9501
 www.t-mar.com

Wide Leg Assembly, 66" ED Mk3

DRAWN BY: Eric Bailke	DATE: 21/04/2017	PART NO.:
REFERENCE NO.:	REVISION:	
606B1192	A	206B1063

SECTION A-A
 SCALE 2X

Grapple Cylinders

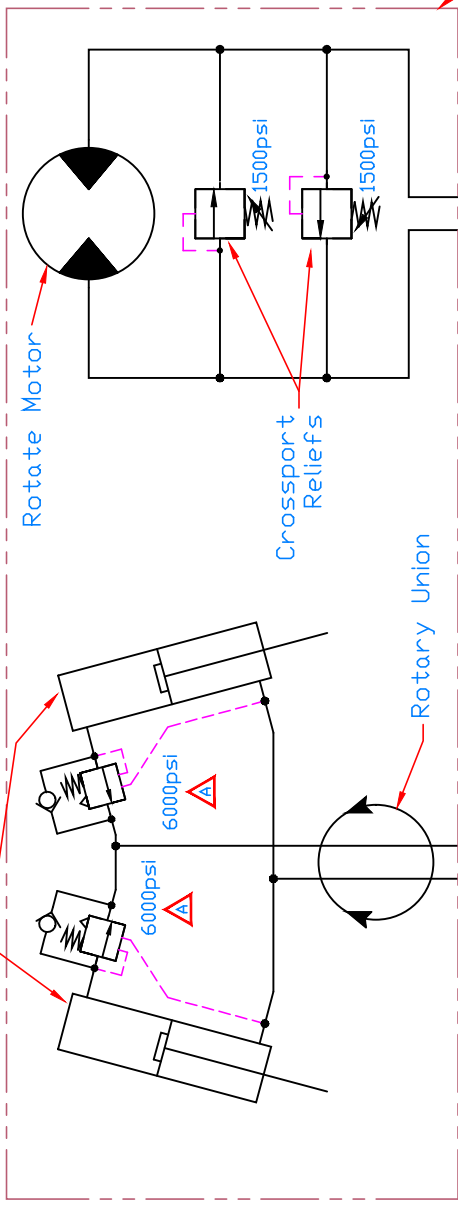

Pressure and Flow Recommendations
 Dual Cylinder Extreme Duty Grapples with High Pressure Cylinders and Rotary Union

- Open / Close Circuit
 Maximum Recommended Flow - 80 GPM
 Recommended System Pressure - 4000 PSI
 Maximum System Pressure - 5000 PSI
 Maximum Port Relief Setting - 5500 PSI
 Minimum Piping Size - -12 (-16 Preferred)
 Counterbalance Valve Setting - 6000PSI
- Grapple Rotate Circuit
 Recommended Flow - 8-12 GPM, 12 GPM Max.
 Recommended System Pressure - 1200 PSI
 Maximum System Pressure - 1300 PSI
 (Crossport Reliefs Factory Set at 1500 PSI)

Components Supplied as Part of the Grapple

Flow should be set to achieve a closing time of 1.0-2.0 seconds.

Flow required to achieve 1.7s closing time:
 Mk2 Grapple: 60 GPM (ED60)
 Mk3 Grapple: 70 GPM (ED66, ED72)

Port Reliefs and Makeup Checks must be provided as noted.

TOLERANCES
 DECIMALS ± 1/32
 FRACTIONS ± 1/16
 ANGULAR ± 1°
 FABRICATIONS ± 1/16
 DO NOT SCALE DRAWING
 UNLESS OTHERWISE SPECIFIED:
 DIMENSIONS ARE IN INCHES

Reference Job Number
 ISSUE DATE:
 2018/03/12
 DESTROY ALL PREVIOUS PRINTS.

Y	M	D	REVISION	BY	REV
18	06	19	Max Permissible swing system pressure was 2000.	EB	D
18	03	09	Changed flow recommendations, crossport pressures	EB	C
16	06	03	Added part label information.	EB	B
15	10	28	Cylinder counterbalance valve setting was 5500 psi.	AL	A

5791 Duncan Bay Rd.
 Campbell River, B.C.
 V9H 1N6

18565-96th Avenue
 Surrey, B.C.
 VAN 3P7

Hydraulic Schematic (High Pressure)
 ED Grapple

DRAWN BY: JM
 DATE: Jan 27 2015
 DWG. NO.: 506B1006
 CHECKED BY: SCALE:

REV: D
 SHEET 1 OF 1